

B-B
SCALE: 1 : 1

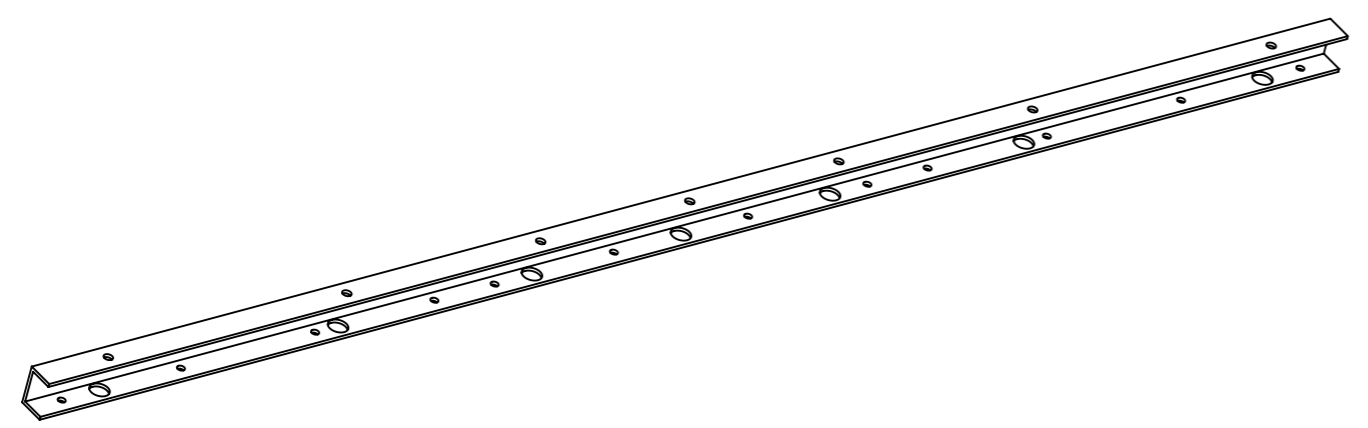
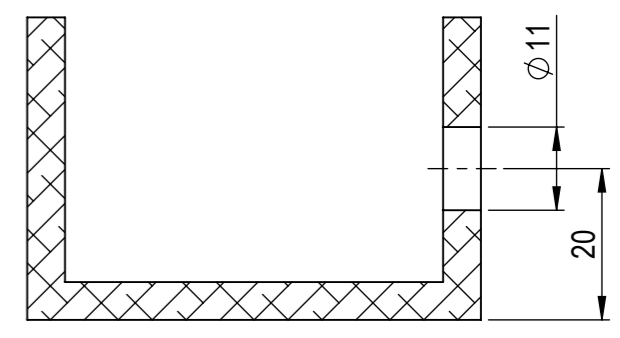

RAW MATERIAL INFORMATION	
Profile size	U 40x60x40x5
Length, mm	2177.5

	MATERIAL	6060F22 T6	WEIGHT	3.735 Kg	DEBURR AND BREAK SHARP EDGES	REVISION	DATE	
	SURFACE PROTECTION	Anodizing ISO 7599:2010	MACHINING	ISO 2768 mK	DO NOT SCALE DRAWING		9/10/2025	
	NAME	SIGNATURE	PART NO.	106-01150-02			SCALE	FORMAT
Designed by	D. Dislers			DESCRIPTION			1:10	A3
Drawn by	K. Sulcs			Aluminum U-profile 2				
Technical ref.								SHEET 1/1